

# Honeywell

# F115 Ceiling Surface Mounted Media Air Cleaners

## PRODUCT DATA



- Two levels of filtration:
  - 99.97% High Efficiency Particulate Air (HEPA)
  - Hospital grade filter 95% efficient at 0.3 micron (MERV 16)
- F115 single speed models deliver up to 600 cfm (1020 m<sup>3</sup>/hr).
- Select models include CPZ™ disposable canisters for odor control.
- Light colored covers complement the ceiling finish.
- Available in 120 Vac, 60 Hz

## GENERAL

The F115 Ceiling Surface Mounted Media Air Cleaners use direct-drive, forward curve, blower/motors with 95% D.O.P. (MERV 16) particle or HEPA filters to remove airborne contaminants. The air cleaners are designed for use in restaurants, conference rooms, lounges and offices where overhead air cleaning is required. They provide their own air circulation, so the air cleaners can be used in any situation that requires the reduction of contamination from an enclosed area.

## FEATURES

- High Efficiency Particulate AIR (HEPA) filter models are 99.97% efficient and the D.O.P. particle filter models are 95% efficient at 0.3 micron particles. Both models are more efficient on particles smaller and larger.

## SPECIFICATIONS

### IMPORTANT

*The specifications given in this publication do not include normal manufacturing tolerances. Therefore, this unit may not exactly match the listed specifications. This product is tested and calibrated under closely controlled conditions, and some minor differences in performance can be expected if those conditions are changed.*

**Models:** Refer to Table 1 for model descriptions.

**Color:** White cabinet and cover

**Blower/Motor:** Single-speed, direct-drive, forward curve.

**Dimensions:** See Fig. 1 for dimensions.

Table 1. F115 Description

Model	Input Power	Filter Rating	Approximate weight of CPZ™ sorbent filters (pounds)	Air Volume in CFM (m <sup>3</sup> /hr)
F115A1064	120 Vac, 60Hz, 1PHS, 7.2A	99.97% HEPA	N/A	600 (1020)
F115A1005	120 Vac, 60Hz, 1PHS, 7.2A	95% at 0.3 micron (MERV 16)	16	600 (1020)



68-0201-05

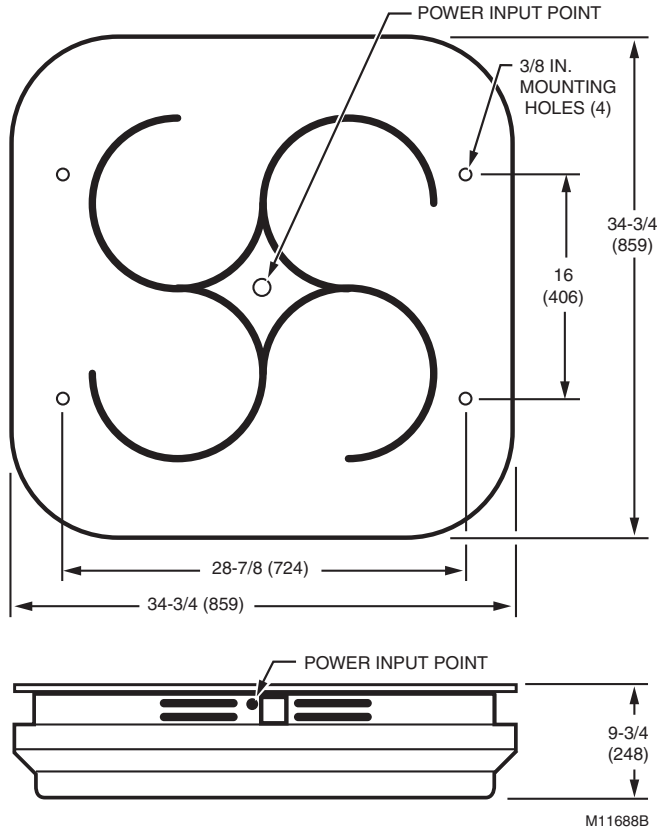

**Fig. 1. Approximate dimensions of F115 in in. (mm).**

**Installation Weight:** Approximately 80 lbs (36 kg)

**Controls:** Direct wired

**Sound Level at 3.3 ft (1 m):** 52 to 56 dBA

**Replacement Parts and Accessories:** See Table 2

## PLANNING THE INSTALLATION

### **⚠ WARNING**

**Electrical Shock Hazard. Power source can cause personal injury.**

- Do not damage electrical wiring or hidden utilities when cutting or drilling into the wall or ceiling.
- Do not install where the media air cleaner can be reached from a tub or shower.
- Always turn off the power at the service panel. Lock the panel to prevent the power from being switched on accidentally when servicing or cleaning the media air cleaner.

### Choose Location

The air cleaner is mounted horizontally and can be used in almost any air cleaning application. For the most efficient operation, centrally locate the air cleaner to the area to be cleaned.

For the best air patterns, avoid discharging the air directly at an obstruction such as a ceiling beam, decorative cornice or pillar. The discharge air pattern has a range of 20 to 25 ft (6 to 7.5m) at full speed.

### **IMPORTANT**

*Do not install at heights greater than 16 ft (4.8m). When multiple air cleaners are needed for a large area, divide the space into equal areas and centrally mount the air cleaners. See Fig. 2.*

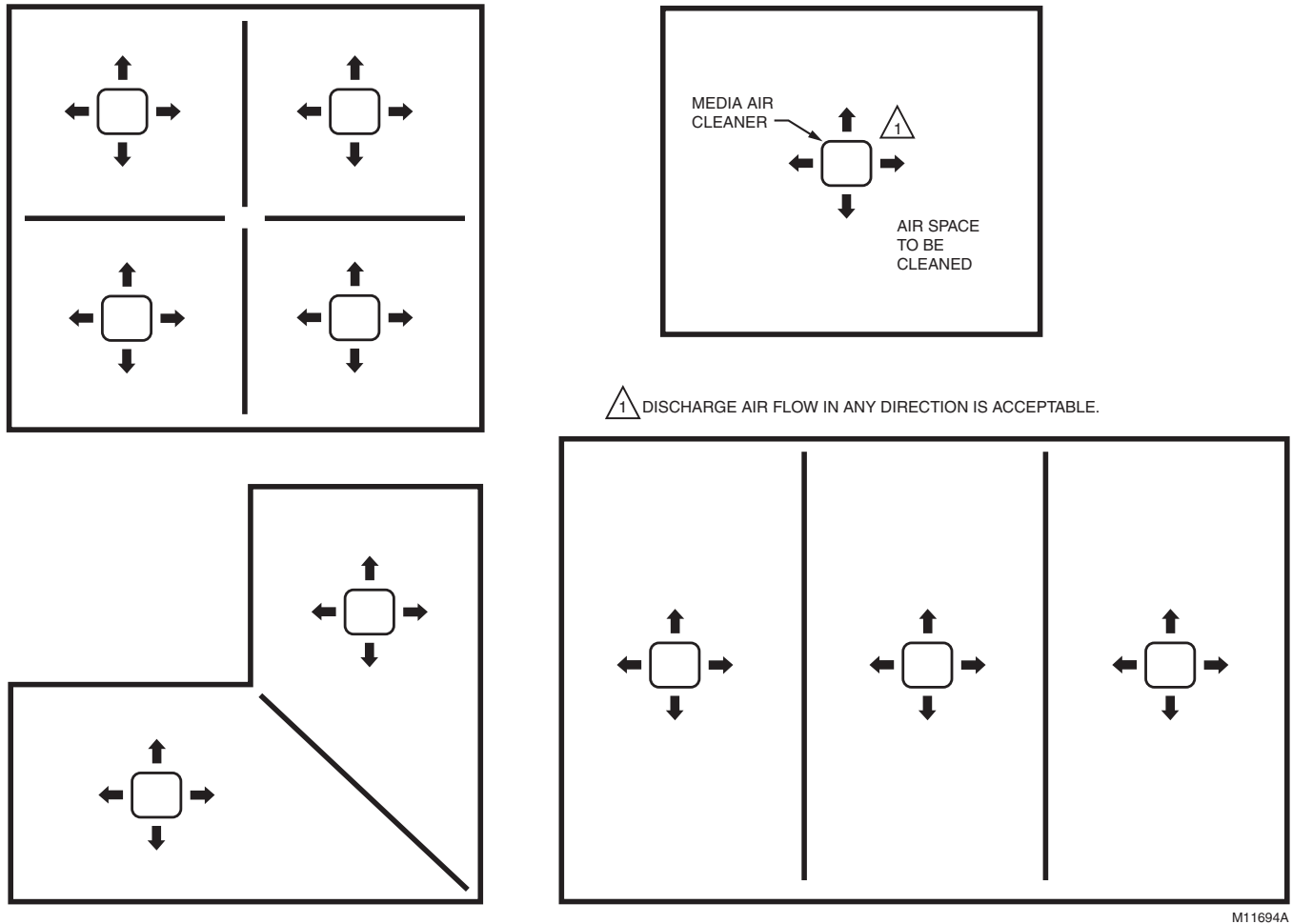

Fig. 2. Choose location for air cleaners.

**IMPORTANT**

When selecting a location, make sure the air cleaner is secured to ceiling load-bearing supports or joists. If installing on a T-grid drop ceiling, secure the air cleaner to the true ceiling.

**INSTALLATION**

**When Installing this Product...**

1. Read these instructions carefully. Failure to follow them could damage the product or cause a hazardous condition.
2. Check the ratings given in the instructions and on the product to make sure the product is suitable for your application.
3. Installer must be a trained, experienced service technician.
4. After installation is complete, check out product operation as provided in these instructions.



**CAUTION**

**Electrical Shock Hazard.  
Power source can shock.**

- Do not connect the power source until after the air cleaner is mounted. This will prevent electrical shock or equipment damage.
- Be sure to turn off the air cleaner before servicing it.
- If the air cleaner must be turned on for an electrical check, be extremely cautious.
- Be cautious when working near the moving parts of the air cleaner.

M11694A

## Mount and Wire the Air Cleaner

### CAUTION

**Eye Exposure.**

**Harmful dust can obstruct or injure unshielded eyes.**

A CPZ™ module usually releases dust when it is handled.

Always wear safety glasses when installing or removing CPZ™ canisters.

### IMPORTANT

*When installing the air cleaner, be sure to follow all local codes and accepted practices.*

1. Decide if the air cleaner wire connections will be from the top or the side. Make the necessary wiring provisions at the ceiling.
2. Grasp the air cleaner cover edge near the plenum and remove the cover from the support brackets. Set it aside.
3. Loosen and remove the filter securing nuts, holding plates and filters. Set them aside.
4. Insert fastening hardware (lag bolts, eye bolts or threaded rod) through the 3/8 in. (10 mm) mounting holes in the filter/motor bases. See Fig. 1.
5. Secure the air cleaner to the ceiling load bearing supports or joists. If installing on a T-grid drop ceiling, secure the air cleaner to the true ceiling.
6. Fasten the plenum assembly snugly against the ceiling.

### IMPORTANT

*Do not over-tighten the plenum fasteners which can collapse or break the plastic base/plenum.*

7. Connect the power. See Fig. 3.

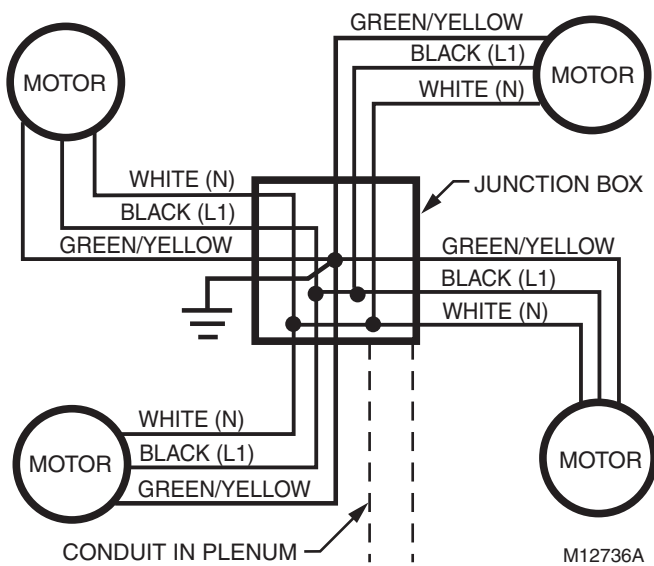

**Fig. 3. F115 Media Air Cleaner (120, 60 Hz) typical wiring diagram.**

### IMPORTANT

*Make sure the air cleaner is grounded for proper operation and safety.*

8. Turn on the power and check that the blowers are operating freely.
9. Position the filter cartridges on the filter base.
10. Insert the CPZ™ cartridge with the cartridge base notches against the motor towers.
11. Attach the filter cover plates.
12. Replace the air cleaner cover.

## OPERATION

The F115 Ceiling Surface Mounted Media Air Cleaners provide their own air circulation. When the air cleaner is powered, the blower/motor draws the contaminated air into the air cleaner. Particles that are too small to be caught in the prefilter are removed by the particle or HEPA filter. The cleaned air is then returned to the building space.

In areas with ceilings up to 10 feet high, the F115 models can clean a 600 to 1200 sq ft (54 to 108 sq m) area.

## SERVICE

The air cleaner removes a variety of particulate contaminants from the air. In the process of cleaning the air, the air cleaner filters become dirty.

To maintain a high standard of reliability and efficiency, it is necessary to periodically service the air cleaner. The filter life is determined by the quantity and type of contaminants present and the frequency of air cleaner use. In relatively clean spaces, the filter life can extend as long as 30 months. In areas that are very smoky and dusty, filters need to be replaced sooner. The frequency of servicing can only be established after a period of use.

NOTE: Some Full-Service Distributors provide regular servicing to commercial establishments.

### CAUTION

**Electrical Shock Hazard.**

**Power source can shock.**

- Turn off the power to the air cleaner when cleaning or servicing.
- Stand on a stable platform when working with the air cleaner.

### CAUTION

**Eye Exposure.**

**Harmful dust can obstruct or injure unshielded eyes.**

A CPZ™ module usually releases dust when it is handled.

Always wear safety glasses when installing or removing CPZ™ canisters.

1. Grasp the edge of the air cleaner cover near the plenum and remove the cover from the support brackets. Set it aside.
2. Remove the prefilters.
3. Check the prefilters and replace them if they are fully coated with dust and lint (approximately every 1 to 3 months).
4. Replace the CPZ™ cartridge when a continuous noticeable odor is emitted from the air cleaner (approximately every 4 to 12 months).
5. Replace the primary filter when there is a noticeable loss of air volume circulation (approximately every 10 to 24 months).
6. Reassemble the air cleaner and turn the power on.

## PARTS LIST

Refer to Table 2 and Fig. 4 for a parts list and an exploded view of the parts.

**Table 2. F115 Ceiling Surface Mounted Media Air Cleaner Parts List.**

<b>Fig. Reference No.</b>	<b>Description</b>	<b>Pack Qty</b>	<b>Order Number</b>
1	Blower Wheel		
2	120V, 60 Hz, Single-Speed Motor		
3	Mid-plate		
4	Prefilter (1 box)	4	32000229-001
4	Prefilter (1 Case)	40	32000230-002
5	HEPA filter (requires 4)	1	32000206-001
5	D.O.P. Particle filter (MERV 16) (requires 4)	1	32000217-001
6	Disposable CPZ canister (requires 4)	1	32000232-002
7	Filter holding plate with stud and nut		
8	Lid/cover		

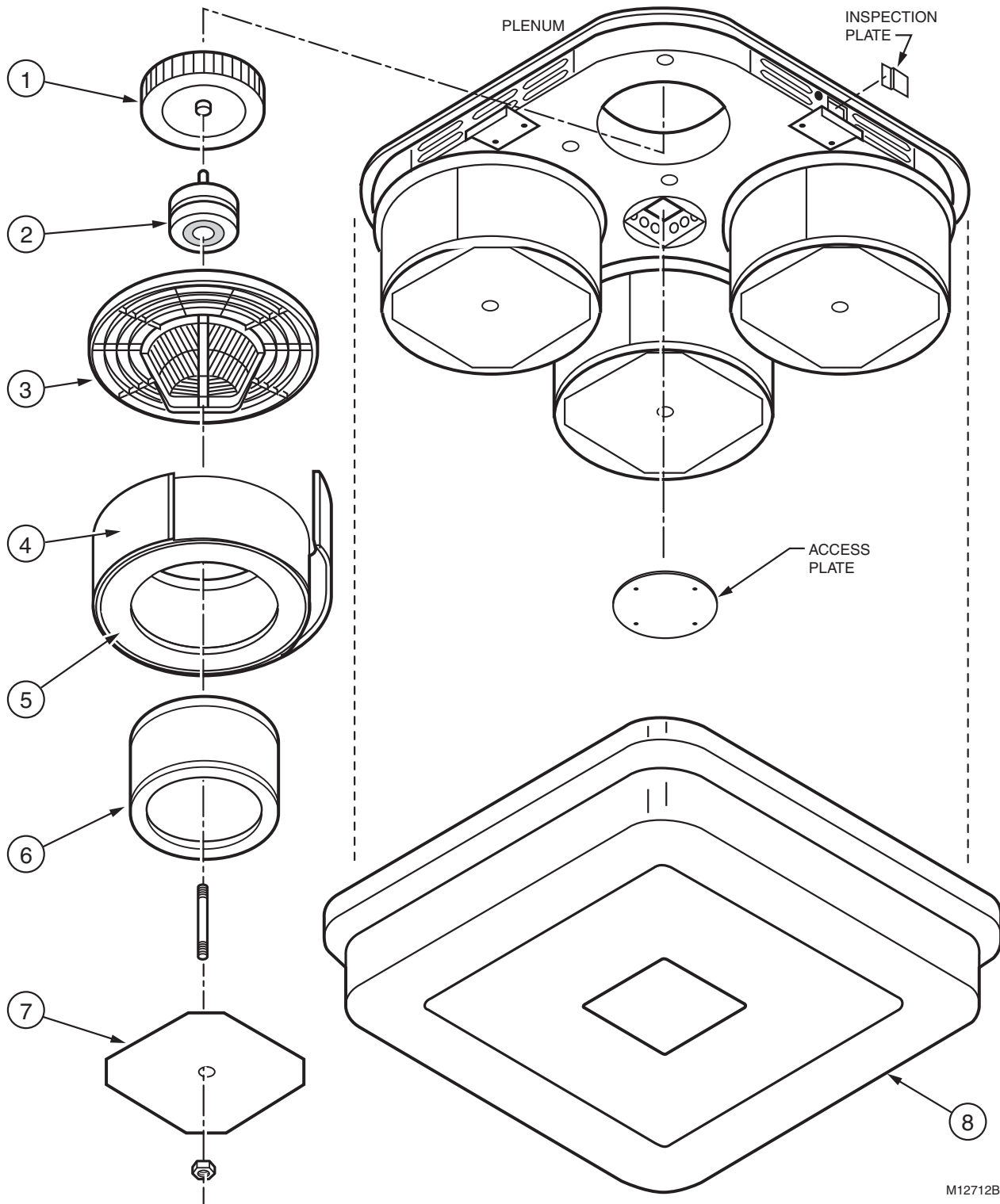

**Fig. 4. Exploded view of F115 Ceiling Surface Mounted Media Air Cleaner components.**



**Honeywell Building Technologies**

In the U.S.:

Honeywell

715 Peachtree Street NE

Atlanta, GA 30308

[customer.honeywell.com](http://customer.honeywell.com)

® U.S. Registered Trademark  
©2020 Honeywell International Inc.  
68-0201-05 M.S. Rev. 08-20  
Printed in United States

**Honeywell**