

WCP Outdoor Call Point Range

WCP5 Intelligent Model - Advanced Protocol (Red Versions)



> Product Benefits

- Sealed to IP67
- Unique 'Plug & Play' installation concept
- Total 'Flex-Ability' in the choice of operating element
- Anti-Tamper facility
- Enhanced aesthetics and compact design
- Fully approved to the latest standards
- CPD Approval



Product Overview

Installation efficiency, flexibility and full compliance with the latest standards are at the heart of the new WCP outdoor call point range.

The outdoor WCP is an IP67 sealed manual call point product. The enhanced environmental protection allows the unit to be installed in many external environments where water and dirt are likely to be present, making it a true waterproof and outdoor product.

Installation time and ultimately cost, are of paramount importance to any fire or security installer. The WCP range directly reflects this need by providing a unique 'plug and play' concept designed specifically to reduce installation time. All new WCP products utilise a special terminal block, where all initial installation cabling is terminated. This terminal block is then simply connected to the back of the WCP. Simple, but effective with no re-termination required and no time wasted. In addition, all WCP products are supplied with three standard 20mm threaded cable entries, accommodating all types of surface wiring installations.

Through new standards and legislation, both break glass and re-settable operating elements can now be used within a manual call point. To provide you with the greatest 'flex-ability', the new WCP range can be configured as either a break glass or re-settable unit by simply changing from one element to another. No other additional parts or alternative products need to be ordered.

All WCP outdoor call point products also help preserve the integrity of the overall system, as illegal removal of the product lid will result in the call point operating and the system going into alarm.

Full compliance with the latest standards is essential and the new WCP indoor call point range is fully approved to the latest EN54-11 standard. (Compliant markings only).

The WCP5A product has the Advanced Protocol embedded which is fully backwards compatible with older System Sensor protocols. A version of this call point with built in isolation is also available.

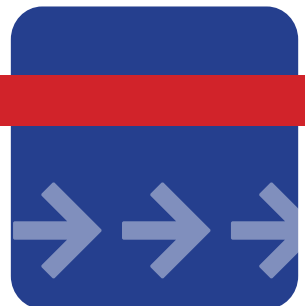

Electrical Specification

Connection Details:	See Figure 1
Cable Termination:	0.5-2.5mm ²
Maximum Voltage:	32VDC
Standby Current:	80μA* (24V, no comms) 120μA* (24V, with comms)
Operating Current:	7.0mA* *figures @ 24VDC

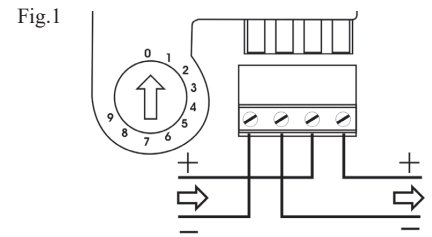

WCP5A

Environmental Specification

Humidity:	93±3% non-condensing
Operating Temperature:	-250C to +700C
Storage Temperature:	-250C to +700C
Ingress Protection (IP) Rating:	IP67
For RoHS, WEEE & REACH data please see	www.kac.co.uk

Mechanical Specification

Material:	PC/ABS
Weight:	350g
Colour:	Red, Ral 3001

Fig. 2

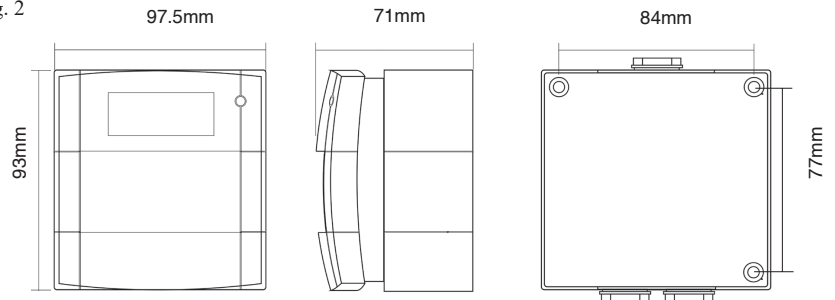

Ordering Information

Model	Isolation	Mounting Element	Operating	Markings
Stock				
WCP5A-RP01SF-K013-01	NO	Surface Flexi		EN54-11
WCP5A-RP01SG-K013-01	NO	Surface Glass		EN54-11
WCP5A-RP02SF-K013-01	YES	Surface Flexi		EN54-11
WCP5A-RP02SG-K013-01	YES	Surface Glass		EN54-11

Accessories

Code	Description
SC070	Pack Of Ten Test Keys
MUS155	Pack Of Five Glass Elements (<i>Also available in packs of 10 & 50</i>)
PS210	Flexible Operating Element
PS200	Plain Hinged Cover
SC071	Pack Of Twenty Terminal Blocks