

# GENT

by Honeywell



FIRE SYSTEM INNOVATORS

## VOICE ALARM GUIDE

Pocket Design & Installation Guide

This guide is aimed at supporting designers on Voice Alarm (VA) and Public Address (PA) systems and their use in conjunction with advanced fire detection systems.

Incorporating the requirements of BS 5839 Part 8: 2013. It highlights some of the main considerations in system design. This guide is intended as an aid and there is no substitute for reading the full standard.



## Contents

### Voice Alarm System Design

- 4. **Regulations for Voice Alarm**
- 5. **Why do we need Voice Alarm**
- 8. **Customer Requirements**
- 11. **System Architecture**



### Loudspeaker Design

- 17. **Loudspeaker Layout**
- 19. **Loudspeaker Types**
- 24. **Loudspeaker Settings**

# Checklist – For designing Voice Alarm Systems

## VA System Design Checklist

To achieve the right VA design a number of simple steps need to be followed. This guide leads you through the steps in a sequence that will deliver a good design.



- ✓ **Regulations for Voice Alarm**
- ✓ **Why do we need Voice Alarm?**
- ✓ **Voice Alarm System Selection**
  - ✓ Management of Evacuation
  - ✓ Voice Alarm System Types
- ✓ **Customer Requirements**
  - ✓ Voice Alarm and Public Address
  - ✓ Microphones and other inputs
  - ✓ Background Music and Entertainment
  - ✓ Messages
- ✓ **System Architectures**
- ✓ **Loudspeaker Design**

## Regulations for Voice Alarm

There is no substitute for a sound knowledge of the standards. **BS 5839 Part 8: 2013** is the code of practice covering the requirements for the design, installation, commissioning and maintenance of Voice Alarm Systems.



It sets out in great detail the steps that should be followed to achieve a system meeting the needs of the application. This guide does not attempt to cover all of the detail of the standard but does set out to highlight the key considerations.

Other standards are also relevant and should be consulted:



**BS EN 5839 Part 1** Design, Installation, Commissioning and Maintenance fire detection and alarm systems

**BS EN 54 Part 16** Design of Voice Alarm Control and Indicating equipment

**BS EN 54 Part 24** Requirements for the design and construction of Loudspeakers

**BS 7827** Code of practice for sound systems at sports venues



## Why do we need Voice Alarm?

Voice Alarm is the future for Fire Alarm Systems

There is some well documented research<sup>1 2</sup> into the behaviour in the event of fire.

Most striking is the variation in the response to alarm signals:

- 13% of people react in a timely manner to bells
- 45% of people react to text information
- 75% of people react in a timely manner to voice messages



What's that noise?



I'm out of here!



"Fire! Please leave the building immediately"

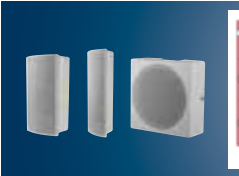

Further research shows that people's behaviour varies dependant on the environment, and in an emergency may exit the building using the same door they used to enter. The use of a clear voice message greatly increases response time and provides the opportunity to advise occupants of the safest emergency route.

\*Source of research data

1: Guylène Proulx, Ph.D.'Misconceptions about human behaviour in fire emergencies' published in Canadian Consulting Engineer, March 1997, pp36, 38.

2: David Cantor, 'Studies of Human Behaviour in Fire: Empirical results and their implications for education and design.' Published by BRE, July 1985.

## Checklist – Management of Evacuation

Before deciding on a VA System design the evacuation requirements of the building must be established



- Is the building to be evacuated all at once (one out all out)?
- or does the building require a phased evacuation plan?

- In the example opposite only part of the building is evacuated immediately
- Whilst other areas will have an alert or standby message

Note: For the Voice Alarm System only 3 circuits are needed to allow separate messages to be broadcast simultaneously.

Front Office	Public bar	Bar & Store
Alarm zone 1	Alarm zone 2	Alarm zone 2
Circuit 1	Circuit 2	Circuit 2
	Public lounge	Staff room
	Alarm zone 3	Alarm zone 3
	Circuit 3	Circuit 3

Loudspeaker Circuit	Location	VA Zone
1	Office	1
2	Bar	2
2	Bar store	2
3	Lounge	3
3	Staff room	3

## Voice Alarm System Types?

Once the evacuation strategy of the building is understood, the designer should assess the type of voice alarm system that should be used.

The level of manual control and the need for live messages versus automated messages will drive the decision on the type of system installed. BS 5839 Part 8 defines 5 types of systems and these are summarised below:



## Types of Systems

### Type V1: Automatic evacuation

This system offers automatic operation of the voice alarm system against a pre-defined evacuation plan. The system may also have facilities for the manual operation of non-fire emergency messages, provided that these are automatically overridden by emergency messages.

### Type V2: Live emergency messages

In addition to the automatic facilities provided by the Type V1 system, the Type V2 system provides the facility for automatic message initiation as well as the facility to broadcast live emergency messages by means of an all-call emergency microphone situated at a strategic controlpoint. This allows supplementary live announcements to aid safe evacuation.

### Type V3: Zonal live emergency messages

In addition to the functions of the Type V2, the facility to broadcast live emergency messages in pre-determined emergency zones, or groups of zones. This allows evacuation control in specific areas of the building where a pre-determined evacuation plan might not cover all eventualities.

### Type V4: Manual controls

Type V4 system has the facility to select and direct stored emergency messages to individual zones as well as the ability to disable or enable emergency broadcast messages and display their status. This allows a well trained and disciplined staff to follow a pre-planned evacuation strategy when the automatic mode needs to be overridden.

### Type V5: Engineered systems

Where the application falls outside the scope of type V1-V4, a type V5 system allows the design of a tailored solution based on the assessment of special or mutable risks.

## Checklist – Customer Requirements

### Voice Alarm and Public Address?

Is the system to be used only for Voice Alarm or a combination of Voice Alarm and Public Address, and maybe even music?



If so, the zoning requirements for Voice Alarm Evacuation may be different from Public Address.

- In the example shown opposite there is a requirement for 3 separate paging zones and 2 areas for music, as well as 3 alarm zones. However there are only 2 evacuation zones.

Note: For the Voice Alarm System only 3 circuits are needed to allow separate messages to be broadcast simultaneously. However once the PA and background music requirements are added the minimum number of circuits required increases to 5.

Front Office Alarm zone 1 Paging No music Circuit 1	Public bar Alarm zone 2 Music No paging Circuit 2	Bar & Store Alarm zone 2 Paging No music Circuit 3
	Public lounge Alarm zone 3 Music No paging Circuit 4	Staff room Alarm zone 3 Paging No music Circuit 5

Loudspeaker circuit	Location	VA Zone	PA Zone	Music
1	Office	1	1	
2	Bar	2		1
3	Bar store	2	2	
4	Lounge	3		2
5	Staff room	3	3	



## Checklist – For designing Voice Alarm Systems

### Customer Requirements – Microphones & Other Inputs

How many microphones are needed and what are they used for? Microphones may be used to broadcast live messages both in an emergency and in normal public address.

For emergency use, microphones must be operated and be monitored in accordance with BS 5839 Part 8, and be certified to the requirements of EN54-16.



Identify opportunities to broadcast miscellaneous announcements. Examples include:

- Spot announcements
- General paging
- Landlord input in shopping centres
- Adverts
- Pre-recorded messages on a PC
- Audio visual presentations

### Customer Requirements – Background Music and Entertainment

Does the system need music, if so how many sources and how is it to be routed? Different areas of a building may need to be linked to entertainment systems. You need to identify the type and location of the music source eg. CD Player, Satellite TV, HiFi System etc.



## Checklist – Messages

What messages do I need to meet the needs of the building?

Recommended messages are defined in the standards, and meet the needs of most buildings. In some cases messages may be tailored to suit special applications and may even involve coded alerts to warn staff ahead of the public.



### Recommend sequence of message and tone

<b>Attention-drawing signal</b>	lasting 2 s to 10 s followed by
<b>Brief silence</b>	lasting 1 s to 2 s followed by
<b>Evacuate message</b>	followed by
<b>Silence</b>	lasting 2 s to 5 s

Example of an evacuate message:

“Attention, please. Attention, please.  
Fire has been reported in the building.  
Please leave the building immediately, by the nearest exit.  
Do not use a lift.”

Example of an alert message:

“May I have your attention, please.  
May I have your attention, please.  
Fire has been reported in the building.  
Please listen for further instructions.”

## Checklist – System Architectures

### Architecture – Centralised or Distributed

The system architecture may be selected to suit the building.



### Some of today's solutions

Three main variations of providing voice messages are available today, these are:

- Stand Alone Voice sounders
- Central Rack Systems
- Distributed Rack Systems

All these types have possible use dependant on the type and size of the building where they are being installed.

### Voice sounders

Although these devices can not be considered a true VA they do offer voice messages, with each device containing a 'memory' chip that has a number of pre-recorded standard messages, that are operated direct from the fire alarm control panel.



It is important that the control panel has a 'synchronisation' capability so all the independent recorded messages are delivered at the same time.

A V1 System is needed.

GENT

## Central Rack systems

Central Rack systems consist of a rack of amplifiers that control all the loudspeaker circuits that are radially wired as shown. This rack can also contain facilities for zone selection, music input, emergency and general paging announcements.



Considerations when using rack systems:

- The link between the fire control panel and the rack must be fully protected and monitored
- The correct cables sizes must be provided for the loudspeaker circuits particularly if they extend across many floors
- The battery standby capacity must be properly calculated with some capacity to extend in the future

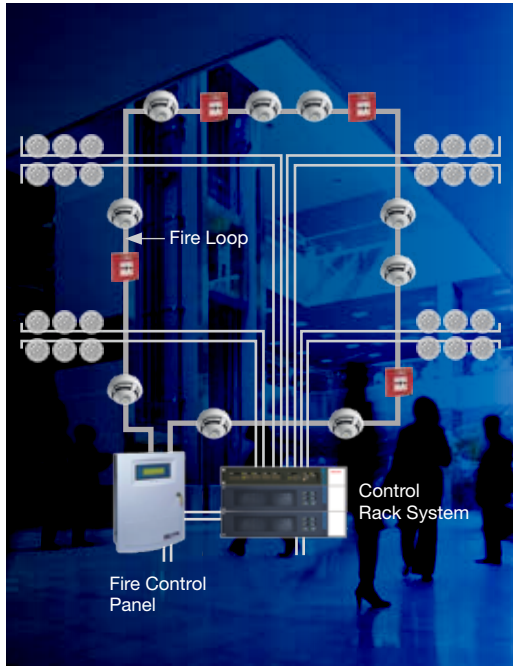

## Distributed Rack Systems

Distributed Rack Systems are the latest innovation that allow the loudspeakers to be connected to local amplifiers often connected on the fire system loop cables, as shown.



**Fibre Optic  
NETWORK**

Configuration

Graphical Management

CD Player

**The benefits of this approach are:**

- There is a lot less cable required for the loudspeaker circuits
- Shorter cable runs to localized racks
- The cables will often be smaller in size and therefore cost less
- The system can easily be extended as additional Distributed Racks can be added to the Voice Alarm network

## Loudspeaker Design – What you need to know...

### Which loudspeaker should I use?

There are potentially several ways of providing intelligible coverage for any particular space. The selection of the type, quantity, location and orientation of loudspeakers is a critical part of voice alarm system design and is based on information about the use of the building such as:

- Acoustic environment
    - floor plans
    - building sections
    - material finishes
    - reverberation time
  - Ambient noise level
  - Climatic environment
  - Area coverage requirement
  - Mounting arrangements, for example ceiling tiles, wall, pole etc.
  - Architectural design and relevance of the appearance of the loudspeaker
- 
- Type of broadcast, i.e. if it is used for purposes other than voice alarm, such as commentary, background music etc.
  - Inter-relationship between loudspeaker zones and fire compartments



## Loudspeaker Layout/Placement

- The best loudspeaker layout should give an even spread of sound within a room
- This may mean using more loudspeakers at lower sound pressure levels rather than one very loud one!

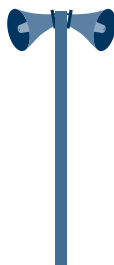

A single loudspeaker at a high setting will give a poor sound distribution.

A number of loudspeakers distributed evenly will give a better distribution and a better quality of sound.

### Bad

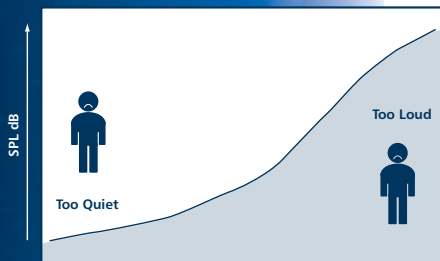

### Good distribution

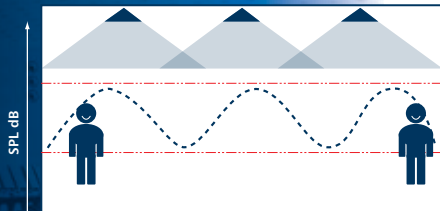

## Checklist – For Loudspeaker Design

BS5839 Part 8: 2013 takes a more prescriptive approach than in previous editions providing simple loudspeaker spacing guidelines for designers.



In simple acoustic spaces, a competent person can estimate types, quantities and locations of loudspeakers required, using the above information. There is a straight forward sequence to follow to arrive at a suitable loudspeaker design.

1 Decide loudspeaker layout / placement

2 Select loudspeaker types

3 Define setting for each loudspeaker

3.1 ✓ Assess background noise levels

3.2 ✓ Decide spacing and tappings

3.3 ✓ Calculate SPL required from loudspeaker

3.4 ✓ Calculate loudspeaker load



## Loudspeaker Layout/Placement

A distributed system will suit most common applications:

- Offices
- Shell and core building systems
- Classrooms
- Shop units



Plan view with ceiling loudspeakers

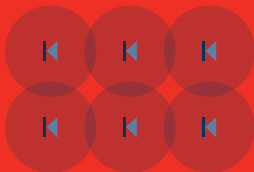

End view of ceiling loudspeakers

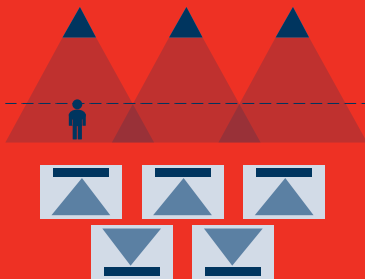

Loudspeakers spaced at regular intervals deliver an even distribution of sound. Listener ear level should be higher than 1.2m unless it's a child or very small person.

Wall loudspeakers may be used as an alternative distributed layout for high ceiling areas.

## Alternative Loudspeaker Layout Options



### Centralised Design and Hybrid or Combined Design

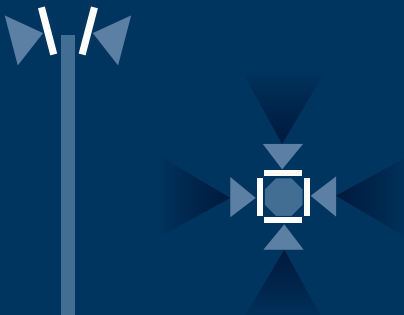

In certain circumstances a centralised design is better suited for example in large open areas.

### Combined

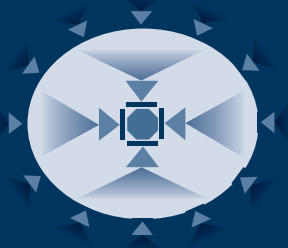

In other circumstances a hybrid of centralised and distributed layout may be required.

## Loudspeaker Selection

### Ceiling loudspeakers

This type of loudspeaker is ideal for open plan offices with false (suspended) ceilings.



Ceiling loudspeakers can give very good music reproduction and are often used in 'low level multipoint' systems where each loudspeaker is tapped at a low level to provide a smooth and even distribution of sound throughout the area of coverage.



### Cabinet loudspeakers

A cabinet loudspeaker provides general coverage within a room of limited size.

Cabinet loudspeakers are suitable for paging announcements in small, quiet offices. Alternatively a number of suitable cabinet loudspeakers can be used in larger office areas to provide sufficient coverage.

Cabinet loudspeakers may also be used as ceiling loudspeakers where a suspended ceiling is not available.



Installations with a large number of ceiling loudspeakers (in an open-plan office, for example) will have them set in a grid pattern to maximize the coverage provided. Ceiling loudspeakers come in a range of diameters and are typically rated at a maximum of 6 watts.

## Loudspeaker Selection

### Horn loudspeakers

Horn loudspeakers have two main attributes: they are weatherproof and are able to direct sound in a well defined pattern. Compact and sturdy 're-entrant' types (folded internally to make the unit shorter) are the most common types.

Due to their restricted low-frequency response, they should be used only for speech applications and amplifier high-pass filtering must be selected. If horn loudspeakers are fed with low frequencies there is a risk of damage to the loudspeaker diaphragms.

### Projector loudspeakers

Projectors are more directional than cabinet loudspeakers but have better musicality than a horn.

The highly directional characteristic of projectors can be useful in saving amplifier power, in areas such as railway stations, a noisy machine shop, car parks and shopping centres.

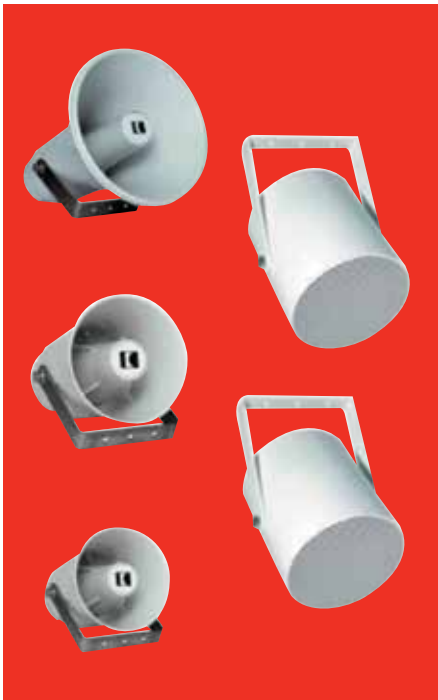

## Loudspeaker Selection

### Column loudspeakers

Column loudspeakers consist of a number of drive units arranged in a vertical pattern and are usually confined to sound reinforcement applications rather than distributed P.A. systems.



They are designed to have a very wide sound dispersion (radiation pattern) in a horizontal plane (from side to side) and narrow dispersion in the vertical plane.

This makes them effective in areas with difficult sound characteristics such as churches, auditoria, railway stations and airports.

### Spherical loudspeakers

Ideal for open areas with high ceilings such as retail units. Sound is distributed around 360 degrees and the sphere is suspended at a convenient height above the floor.

With good sound reproduction quality they are useful for voice and music in difficult applications.



## Loudspeaker Design - Siting of Ceiling Speakers



Ceiling loudspeaker mounted  
in suspended ceiling

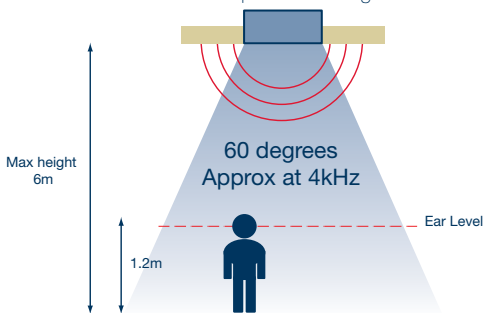

Listener ear level should be higher than 1.2m unless it's a child or very small person.

Ceiling loudspeaker mounted  
in suspended ceiling

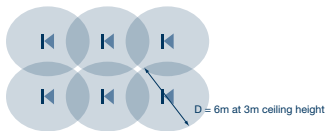
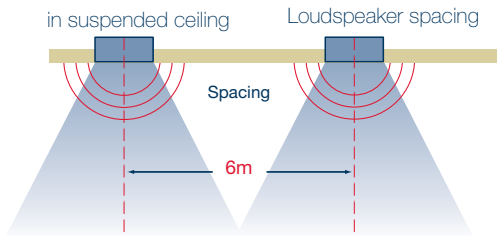

Where ceiling loudspeakers are to be mounted in a suspended ceiling they are to be mounted on a square grid.

Ceiling loudspeakers shall be mounted at a maximum of 6m spacings to comply with the requirements of BS5839-8: 2013

## Loudspeaker Options

### Cabinet loudspeakers layout

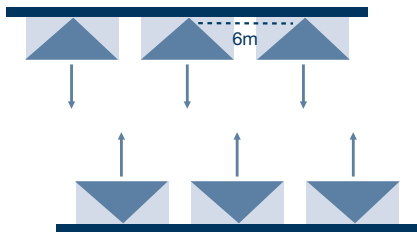

As general guidance, in rooms less than 6m wide, cabinets can be fitted along one wall only. Above 6m the loudspeakers should be fitted to opposing walls.

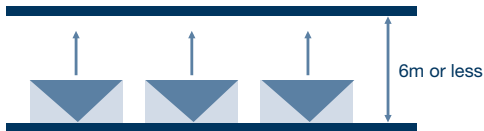

Where loudspeakers are cabinet types to be wall mounted, they should be fitted at a height of 2.5m to 3m and spaced 6m apart along the wall.

Power settings should be set to give 10dB above the background at the furthest point from the loudspeaker.

Take care not to position loudspeakers opposite each other, the sound coverage and intelligibility in the area mid-way between them will not be optimal.

## Define Loudspeaker Settings

As well as layout, an intelligible Voice Alarm System is dependant on the sound level of the broadcast message.

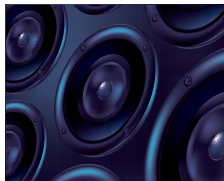

Calculate Sound Pressure Level (SPL) required from each loudspeaker –

Step 1: Assess background noise

The Sound Pressure Level (SPL) required depends greatly on the background noise levels.

Typically the System design should aim to deliver SPL at around 10dB above ambient.

The table gives some typical sound levels in different environments.

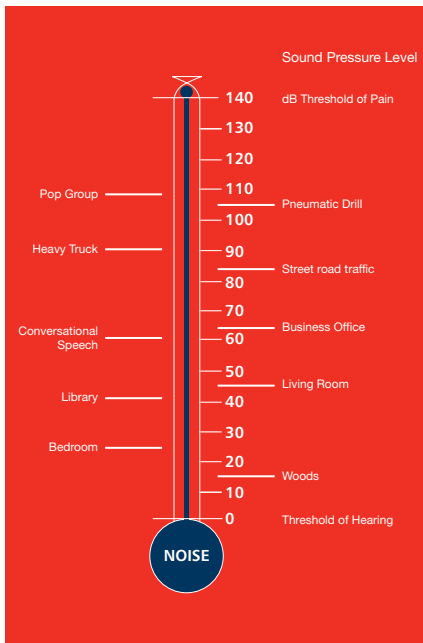



## Define Loudspeaker Settings

Calculate SPL required from Loudspeaker –  
Step 2: Sound pressure level

Sound pressure falls off rapidly with distance and there is a loss of 6dB every time the distance doubles.



To achieve the desired sound pressure at a certain distance away from the loudspeaker, the loss must be calculated.

Distance from source (m)	Reduction in DB (A)
1	0
2	6
3	9.2
4	12
5	13.9
6	15.5
7	16.9
8	18
9	19
10	20

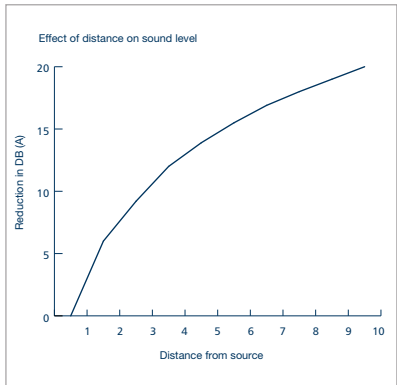

### Example

Distance from loudspeaker	=	4m
Ambient noise level	=	61 dBA
Target SPL (6ldb+10db)	=	71 dBA
DB loss over 4m	=	12 dBA
Loudspeaker setting at 1m	=	At least 83 dBA at 1m

## Define Loudspeaker Settings

Calculate SPL required from each Loudspeaker

### Step 3: Loudspeaker tapping

Once the sound pressure level is known, the tap setting of the Loudspeaker can be defined. Loudspeaker data sheets give the power needed to achieve the SPL at 1m.

The table below can also be used to define typical tap settings for ceiling Loudspeakers at different ceiling heights.

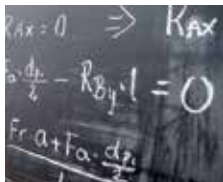

## Typical Tap Settings

Ceiling Height	Background Noise (SPL set to 10dB higher)					
	65dB	70dB	75dB	80dB	85dB	90dB
2.5	0.75	0.75	0.75	0.75	1.5	6
3.0	0.75	0.75	0.75	1.5	3	–
3.5	0.75	0.75	0.75	3	6	–
4.0	0.75	0.75	1.5	6	–	–
4.5	0.75	0.75	3	6	–	–
5.0	0.75	0.75	3	–	–	–
5.5	0.75	1.5	3	–	–	–

## Loudspeaker Design – Assess Background Noise

What size amplifier do I need?

Calculate loudspeaker load: for each circuit

Once you have determined each individual Loudspeaker tapping, the total load for each Loudspeaker circuit can be calculated.

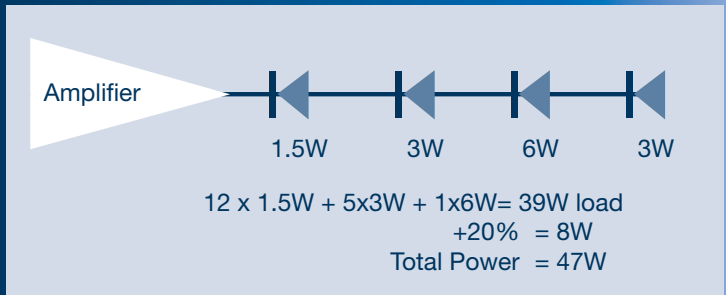

By adding the power requirement for every Loudspeaker the total load for the Amplifier is calculated.

Add 20% for minimum size of amplifier needed (account for efficiency losses on amplifier and cable).

## Gent's VA product range

Gent has a VA solution for all types of buildings and with our team of experts to support you every step of the way, it's never been easier to work with our products.



Three types of systems are available including small 'Stand Alone' packages suitable for single storey buildings such as shops and offices and move up to custom made 'Networked Systems' that will consist of a number of systems linked together for large structures such as exhibition halls and airports.

### Loudspeakers

Our full range of loudspeakers complies with BS5839 part 8 and EN54 part 24 and includes:

- 5" and 6.5" Ceiling Loudspeaker
- 6W Cabinet Loudspeaker
- 10W and 20W Unidirectional Projection Loudspeaker
- 20W Bidirectional Projection Loudspeaker
- 20W and 40W Column Loudspeaker

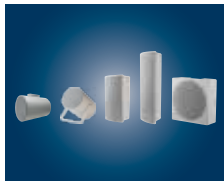

### Support

We offer a full Voice Alarm Support Service including:

- System design
- Acoustic design support and modeling (where required)
- Loudspeaker layouts
- Rack build
- Commissioning support
- Factory acceptance testing
- Training
- Technical Support



For more information go to [www.gent.co.uk/products/voice-alarm-system](http://www.gent.co.uk/products/voice-alarm-system) or call our support services team on **0116 246 2275**