

# DETECT AND DETER FIRE AND GAS HAZARDS

Protect your gas turbine and enable safety-critical functions with state-of-the-art Honeywell solutions that empower you to detect smoke, fire, and toxic leaks in due time.

**Honeywell** | Industrial Fire Solutions

# REST ASSURED KNOWING THAT YOUR FACILITY IS SAFE.

When it comes to safety-critical applications, maintaining a secure environment at all times is crucial to uptime and worker wellbeing. Although you can't predict gas and fire incidents, you can prevent them from leading to disastrous or life-threatening situations.

Forget about the hassle of mass-produced, standalone solutions. Now you can have fire and gas detection along with fire suppression and controls, all integrated into one single system that delivers total fire and gas hazard protection of a modern gas turbine enclosure.

## THE HONEYWELL ADVANTAGE

Honeywell provides you the power and flexibility to fully integrate high-quality, certified devices in a fault-tolerant network. This ensures that your system is always active and available to respond to a demand.

With over a century of experience in the field, Honeywell is the global leader in gas and fire detection technology – offering solutions that are approved by most of the turbine manufacturers and deliver the highest degree of safety and integrity. We offer you tailor-made and easy-to-maintain solutions with the reliable installation and support that safety-critical applications need.

Each day, we deliver on our vision to be the first choice for distributed power and compression system services. Our gas and fire products are used in major oil and gas companies across the world, including Turbine Enclosure Protection solutions for:

- Addressable Fire Detection
- Advance Detection
- Fire and Flame Detection
- Hazardous Gas Monitoring
- Extinguishing/Release Controls
- Notification
- Certified up-to SIL3



**HS-81 FIRE AND GAS  
CONTROL PANEL**



**SEARCHPOINT OPTIMA  
PLUS GAS MONITORING**



**FS24X  
FLAME DETECTOR**



**SEARCHPOINT  
HT SENSOR**



**302-EPM-194  
HEAT DETECTOR**

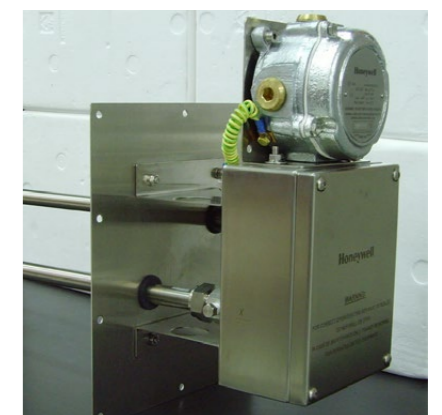

**DUCT WATCH  
SENSOR**

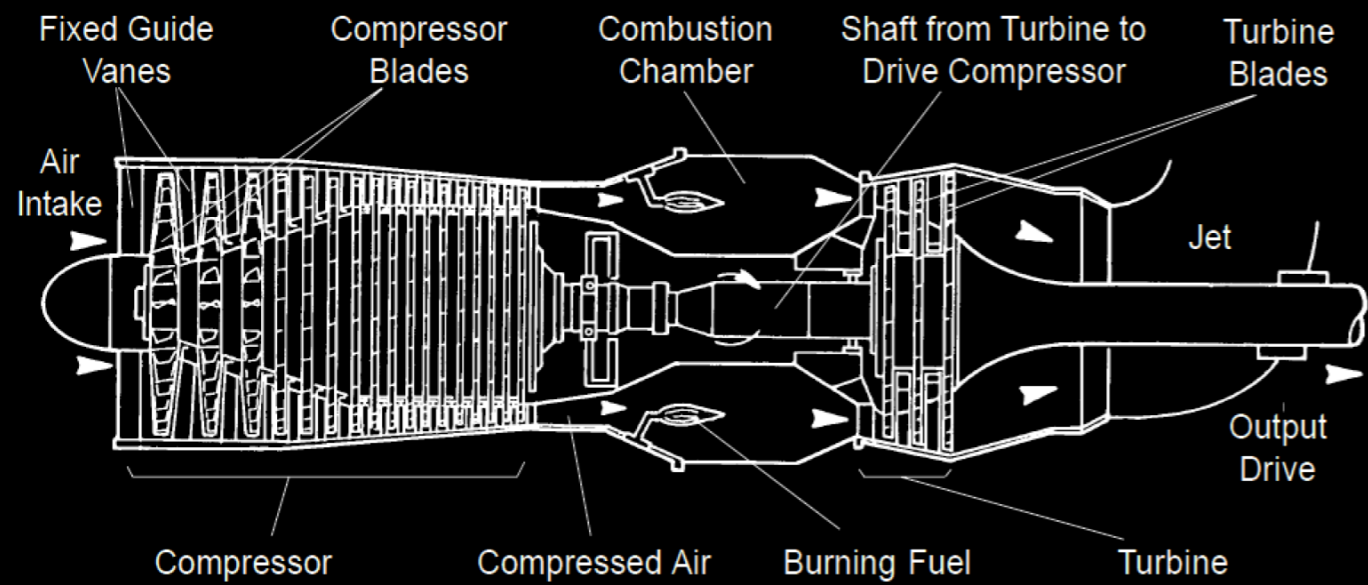

DUCT WATCH SENSEPOINT HT  
SENSOR WITH XNX UNIVERSAL  
TRANSMITTER FLAMMABLE  
WITH HIGH TEMPERATURE

302-EPM-194  
HEAT  
DETECTOR

FIRE  
BEACON

HORN/  
BEACON  
COMBO  
UNIT

FIBER OPTIC  
CONNECTIVITY TO  
MAIN HS-81 F&G  
SYSTEM

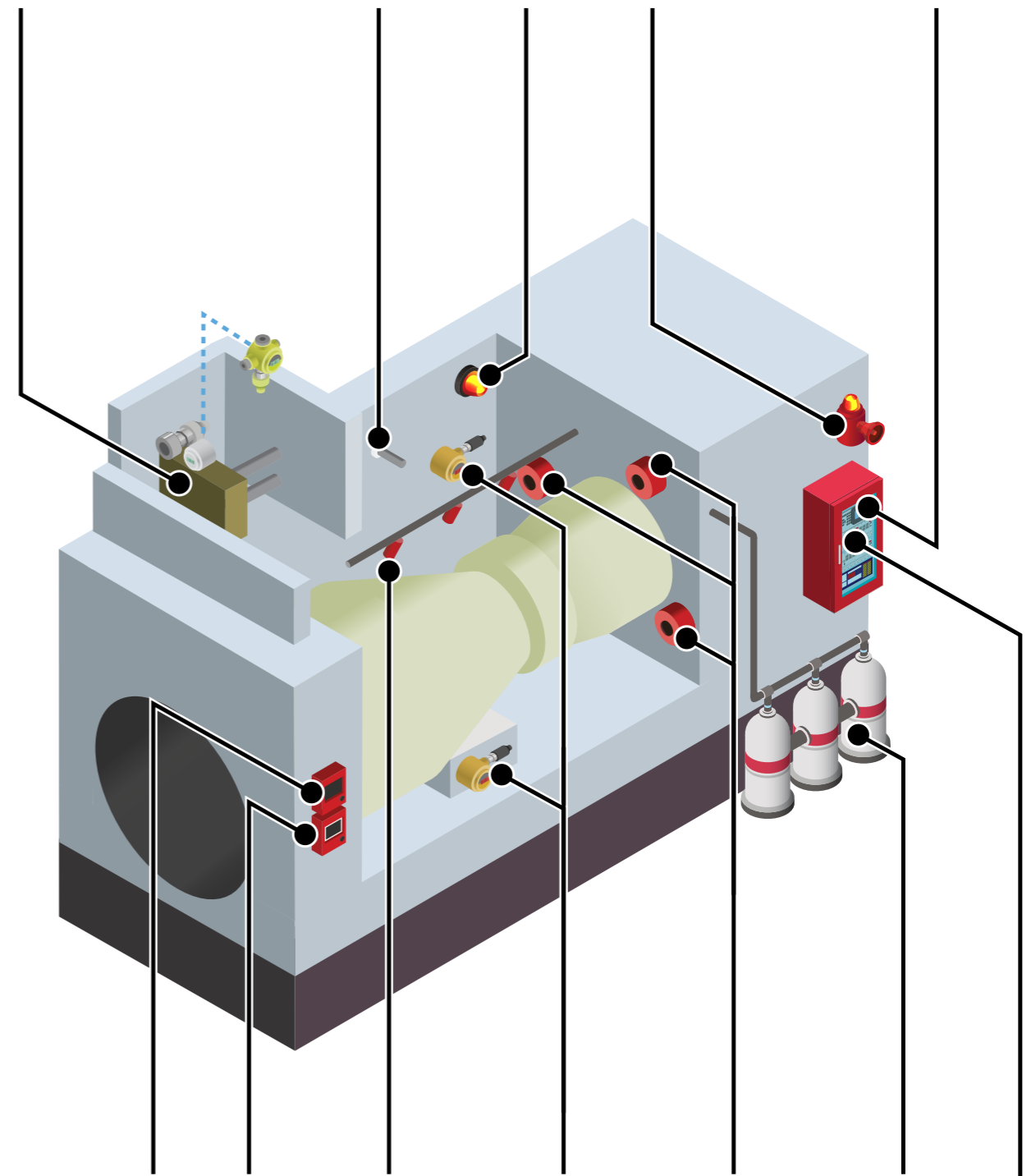

MCP/  
BGU  
MANUAL  
RELEASE  
PULL  
STATION

CO2/  
WATER MIST/  
OTHER

SEARCHPOINT  
OPTIMA PLUS  
GAS DETECTOR  
WITH OELD

FS24X  
FLAME  
DETECTOR

FIRE  
SUPPRESSION

CRITICAL SIGNAL  
EXCHANGE WITH  
TURBINE CONTROL  
PANEL

# GAS TURBINE ENCLOSURE FIRE PROTECTION

Gas turbines are usually housed within acoustic enclosures to protect the turbine and to reduce environmental noise. However, in the event of a gas leak, such enclosures may promote a build-up of gas and thus give rise to an explosion risk. All of this can be prevented with the help of an engineered fire protection design for gas turbine enclosure, which should include:

- Identification of applicable codes, standards, and specifications
- Identification and analysis of all flammable materials present
- Identification of the most likely conditions and scenarios leading to fuel leakage, accumulation, and possible ignition
- Specification and evaluation of detectors and their locations
- Specification and evaluation of automatic fire suppression
- Specification of the fire protection control system and logic
- Integration with the detection and suppression systems

## PINPOINT YOUR BIGGEST RISKS

Identify the most likely places where a fire is probable to occur. With this information, create a priority ranking of all potential fire ignition areas. This ranking, or fire hazard area index, breaks down the application by fire ignition risk. Factors to consider in this process include:

- Flammable materials present, and the likelihood of spillage or leakage (fuel, lube oil)
- Hot surfaces (combustion chamber, turbine expander, exhaust ductwork)
- High-pressure processes (fuel & lube oil supply lines)
- Large volumes of flammable materials (fuel storage tanks)
- High-value items or equipment (gas turbine)

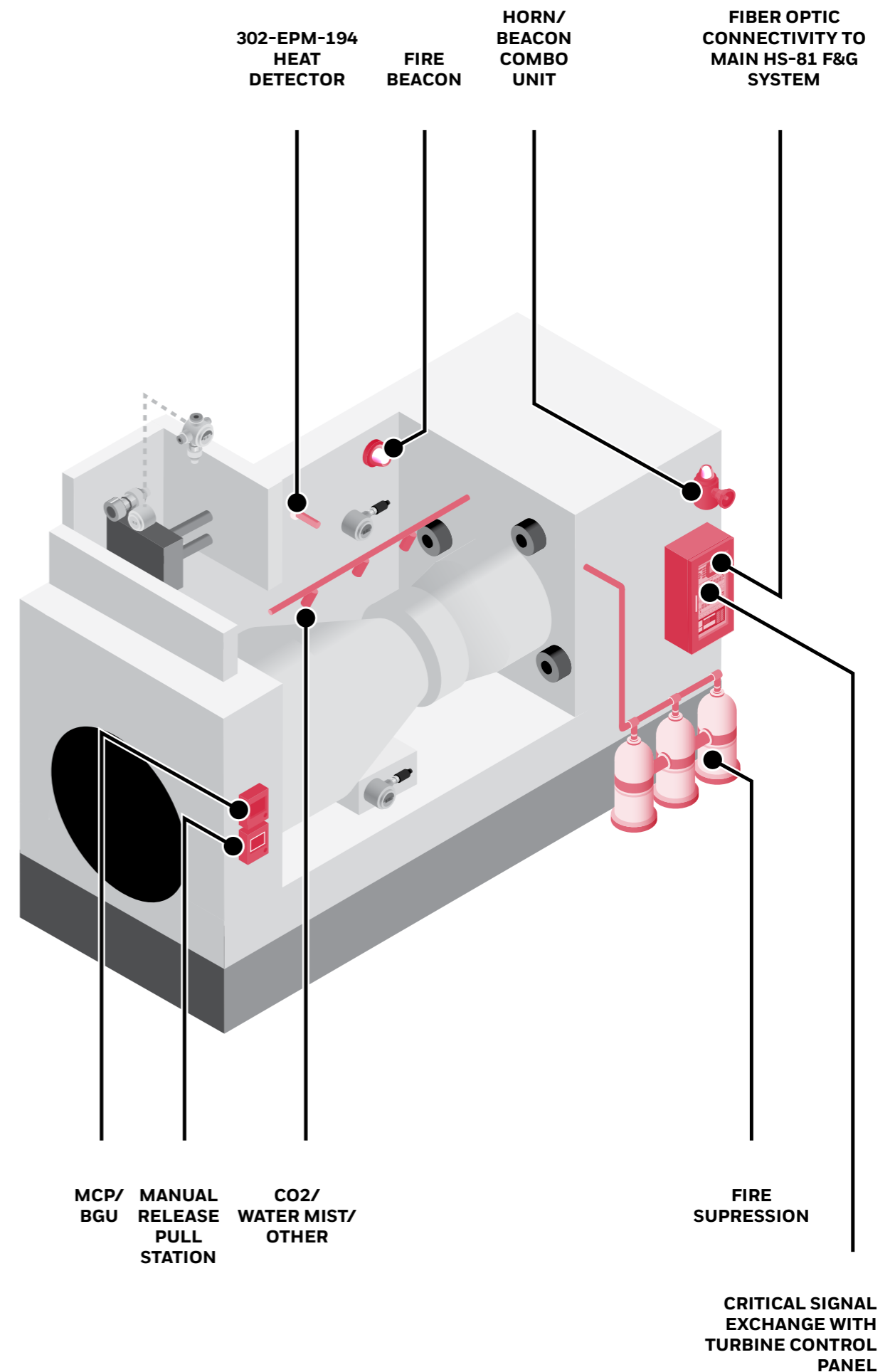

# FIRE AND GAS SYSTEM INTEGRATION FOR GAS TURBINE ENCLOSURES

## SAFETY COMES EASY WHEN YOU HAVE THE RIGHT SET OF TOOLS

An automatic, controlled fire and combustible gas detection and monitoring system is usually installed in the gas turbine enclosure. The fire alarm control panel is the heart of the system, providing alarms, initiating critical actions, allowing agent release, and more.

Offering all of these features and more, the Honeywell HS-81 fire alarm control panel is a high technology product created for monitoring smoke, flame, and gas. HS-81 is easy to configure and program, delivering

excellent reliability and system diagnosis. Suitable for hazardous installations, the HS-81 comes with a modular design and a PLC base architecture. The platform is performance-certified to NFPA72, can be certified up to SIL level 2 or 3, and complies with applicable standards (EN, UL, FM).

This panel, along with other Honeywell industrial fire solutions, delivers you a fully engineered fire and gas control package – empowering you to monitor and protect your property and your assets with confidence.



### FIRE DETECTION

Due to the high value of a gas turbine and relevant fire scenarios, a “belt-and-suspenders” methodology of fire detection is often used. Spot-type heat detectors are recommended as a back-up to optical flame detectors, given their simple and reliable nature.

The temperature alarm point on the detector should be 37.7°C (100°F) above the maximum temperature expected inside the enclosure under normal conditions. Due to the high ventilation rates inside the turbine enclosure, spot heat detectors are often located near the enclosure ventilation exhaust opening to ensure the heat is directed to the detector.

Smoke detectors aren't best suited for turbine enclosures, but they can be used to detect fire inside cleaner and cooler electrical generator enclosures.



### FIRE NOTIFICATION

Fire alarm strobes and horns should be installed both inside and outside the turbine enclosure. NFPA 72 standards require audible devices to have a sound level at 15 dB above the average ambient sound level or 5 dB above the maximum sound level.

However, the device cannot be so loud as to make the sound and ambient levels combined exceed 120 dB. So when it comes to operating turbines, with an ambient sound level that exceeds 105 dB, visual devices become mandatory.



### FIRE SUPPRESSION SYSTEM

There are several suppression agents available on the market for gas turbine enclosure fire suppression. Examples include CO2, FM-200, Argonite, FE-13, NOVEC 1230, and water mist. Contact your Honeywell representative and together we'll choose the best agent to serve your purposes.



### FACP INTERFACE WITH TURBINE CONTROL PANEL

Emergency turbine shutdown is crucial when attempting to prevent a fire from spreading inside your turbine or facility. This is why a NAPA-compliant, fault-tolerant safety system is recommended for safety-critical applications.

## COMMON HAZARDOUS SCENARIOS



### F&G SYSTEM FAILURE OR FAULT

The detection control panel sends a trouble signal to the turbine control panel system to notify the operator.



### SUPPRESSION SYSTEM DISCHARGED

A command is sent to the turbine's ESD to close the fire damper



### HIGH GAS DETECTED

Turbine operations shut down through the ESD system.



### FIRE DETECTED

Turbine operations shut down through the ESD system.



### LOW GAS DETECTION

The vent fan Start request is initiated.



### ENCLOSURE DOOR OPEN

Inhibit the automatic fire suppression and sound local alarms.

# OPTICAL FLAME DETECTION FOR GAS TURBINE ENCLOSURE

When placed properly, optical flame detectors can quickly spot and annunciate fires. Ideal for turbine enclosures, these detectors use new technology sensors, highly reliable and resistant to nuisance alarms – making them ideal for turbine enclosure security.

In the above example, one detector is located high enough to have a clear view over the top of the turbine, but low enough, so it is not in a hot, stagnant air space. The lower optical flame detectors are located one on each side of the turbine. They are oriented to see the side of the turbine, under the turbine, and any auxiliary equipment installed on the floor.

## CHALLENGES

### HIGH TEMPERATURE

Temperatures inside the enclosure can exceed 82.2°C (180°F), especially in the area above the turbine exhaust. With this in mind, we recommend using a sample system to monitor the temperature inside turbine enclosures. For electronic equipment and optical flame detectors, they should be mounted away from the high-temperature areas.

### OIL MIST AND SMOKE

Ruptured lube oil lines can coat the turbine enclosure and become the source of smoldering fires. However, UV and UVIR detectors lose detection range when oil or smoke are present on the UV sensor's window. To best address this challenge choose to install IR detectors.

## RESTRICTED VIEW

Optical flame detectors must be in direct line of sight in order to identify a fire. Consider obstructions when selecting detector mounting locations.

## RECOMMENDED SOLUTION FOR FLAME DETECTION

Most modern UV, IR, UVIR, and multi-IT detectors are designed to identify typical fires associated with turbine enclosures: natural gas, propane, and fuel and lubrication oils. The selection of detection technology for a turbine enclosure relies heavily on nuisance alarm rejection and maintenance. In this light, the wideband, multi-spectrum quantum IR detectors are generally preferred because they have:

- Higher operating temperature
- Long-range and wide field of view
- Visible spectrum improves nuisance alarm rejection
- Faster response and greater sensitivity
- Better noise immunity and performance
- Real-time spectral data is recorded for setup and post-evaluation

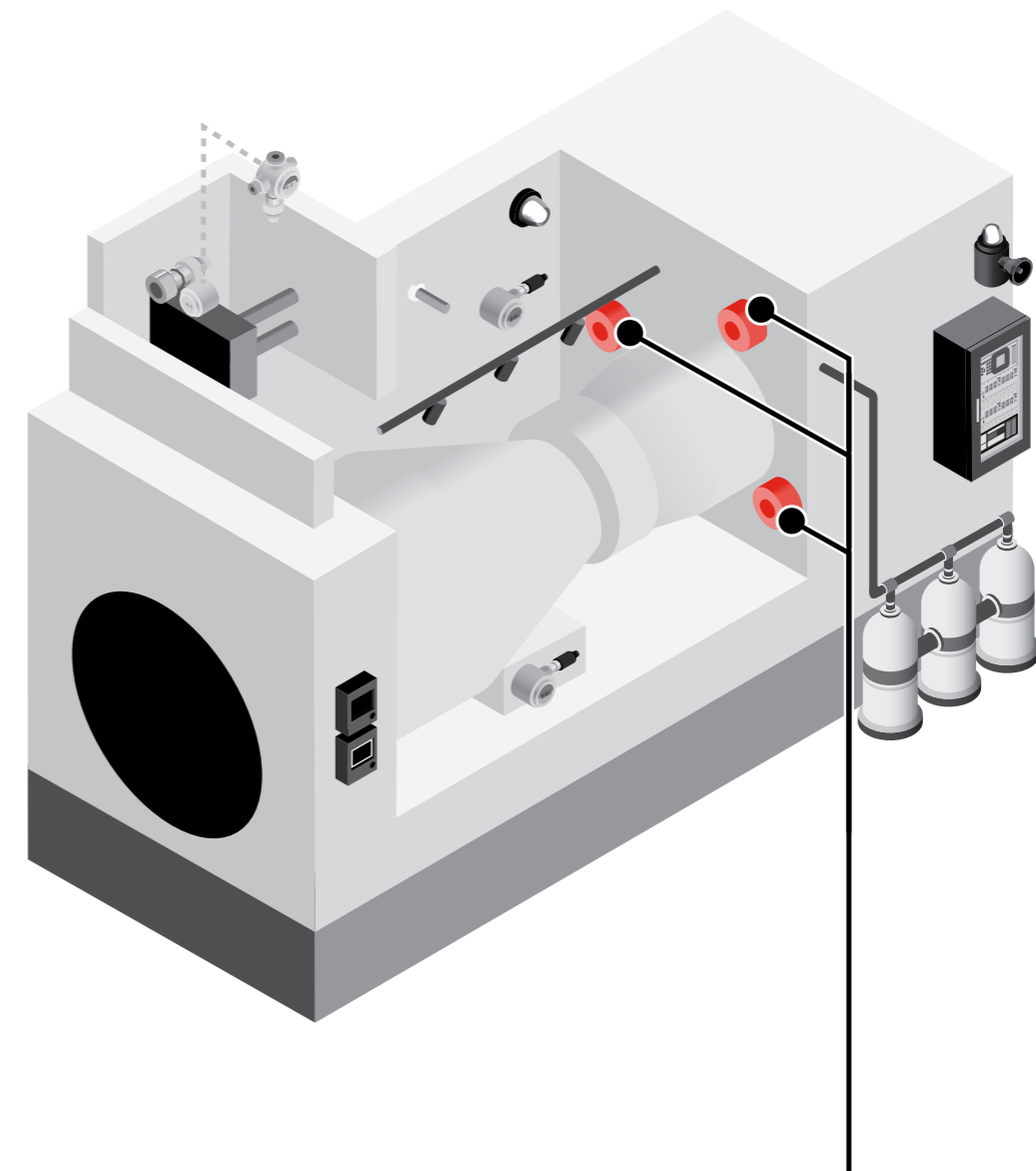

**FS24X  
FLAME  
DETECTOR**

# COMBUSTIBLE GAS DETECTION FOR TURBINE ENCLOSURE

## CHALLENGES

Proper selection of gas detection solutions for turbine applications always starts with the identification and analysis of all flammable materials present on-site. Once this step is completed, pinpoint the most likely to happen scenarios and conditions related to the release of flammable vapors, gases, and even possible ignition. After you gather and analyze this information, you are prepared to select a gas detector that best meets your facility's needs.

Identification of gas leak behavior, gas migration path, and potential areas of gas

accumulation often require simulation testing (smoke tests) in order to gather meaningful data.

## RECOMMENDED GAS DETECTION TECHNOLOGIES

### DUCT WATCH SENSEPOINT HT SENSOR WITH XNX TRANSMITTER

In the model illustrated below, the catalytic gas detector model Sensepoint HT is used with a Duct Mounting Box (DMB) which provides reliable detection of gases within an air handling duct. Sensepoint HT detectors are a reliable solution to detect flammable gases, gas leakage in the ambient, with a sampling system and inside ducts.

Commonly these types of detectors are suitable for all applications, with the exception of installations where there is no oxygen or where the presence of chloride substances and silicones is possible. In that case, infrared technology is the right choice to best detect flammable gases.

The Sensespoint SIL2 catalytic gas detector will further connect to the XNX Universal transmitter – offering access to manual readings and safely transmitting to the HS-81 panel. Other technical details are illustrated bellow.

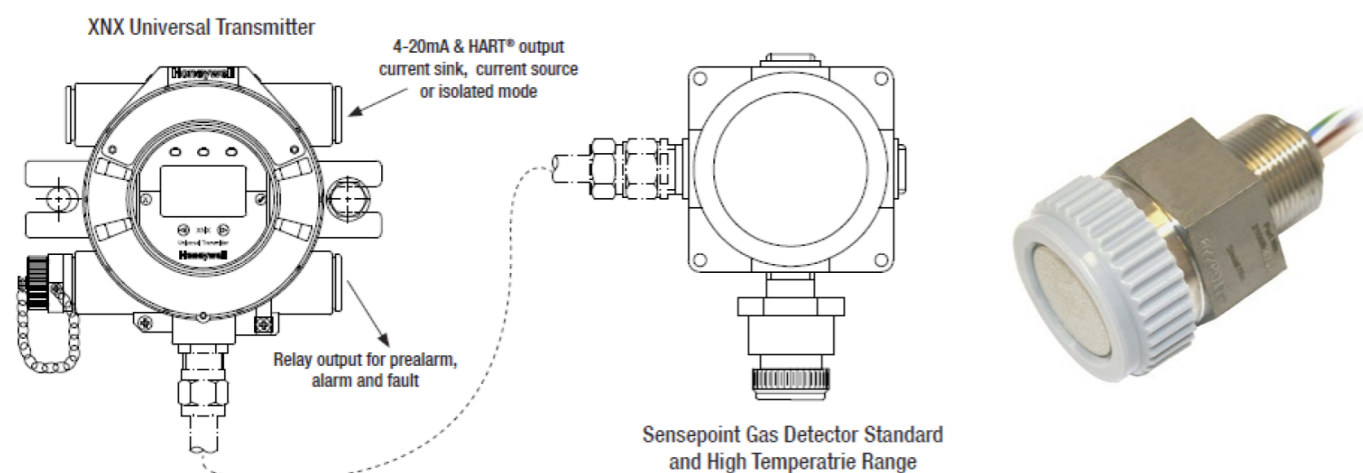

DUCT WATCH SENSEPOINT HT SENSOR WITH XNX UNIVERSAL TRANSMITTER FLAMMABLE WITH HIGH TEMPERATURE

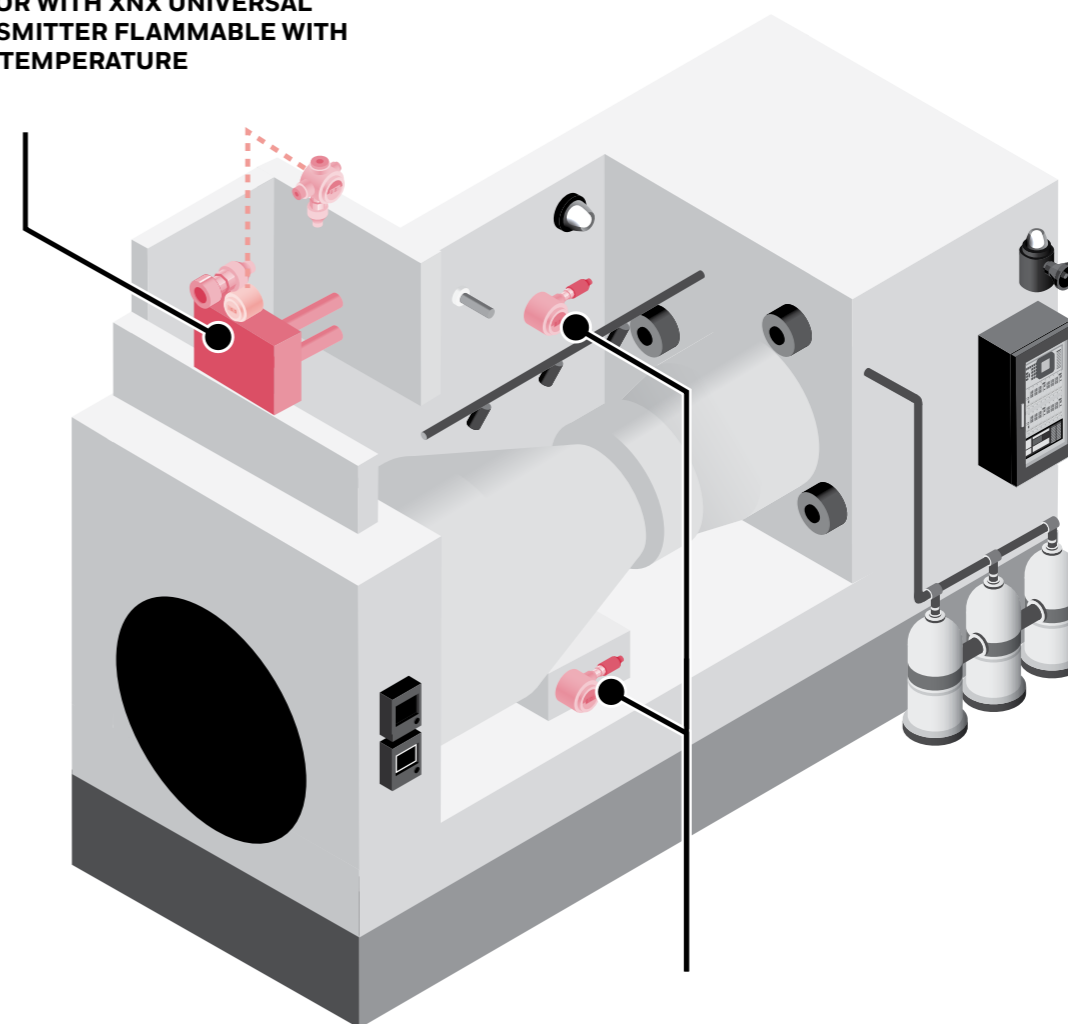

SEARCHPOINT OPTIMA PLUS GAS DETECTOR WITH OELD

## SEARCHPOINT OPTIMA PLUS

The infrared gas detector model Searchpoint Optima Plus is a well-proven technique that uses a sampling system to efficiently detect flammable gas and gas leakages in the ambient. Given their long-term stability, the calibration period of these detectors can be extended to six months.

Certified up to SIL-2 level and classified as a type B1 device according to IEC 61508, the Searchpoint Optima Plus IR gas detector has a hardware fault tolerance of "0" and offers a Safe-Failure fraction from 90 to 99%.

In turbine applications, the Searchpoint Optima Plus detector is directly connected to the HS-81 panel through the 4-20mA protocol with 0-100% LEL. The alarm setpoints are made directly on the control system connected. This low alarm setting imposes to reduce the time of calibration, in order to maintain zero drift steadily.

The Searchpoint Optima Plus detectors are not affected when exposed to poisonous substances and can even function in spaces without oxygen – making them a perfect match for applications of all types.

# FIRE AND GAS DETECTION ARCHITECTURE FOR GAS TURBINES

## INDEPENDENT GAS TURBINE CONTROLS

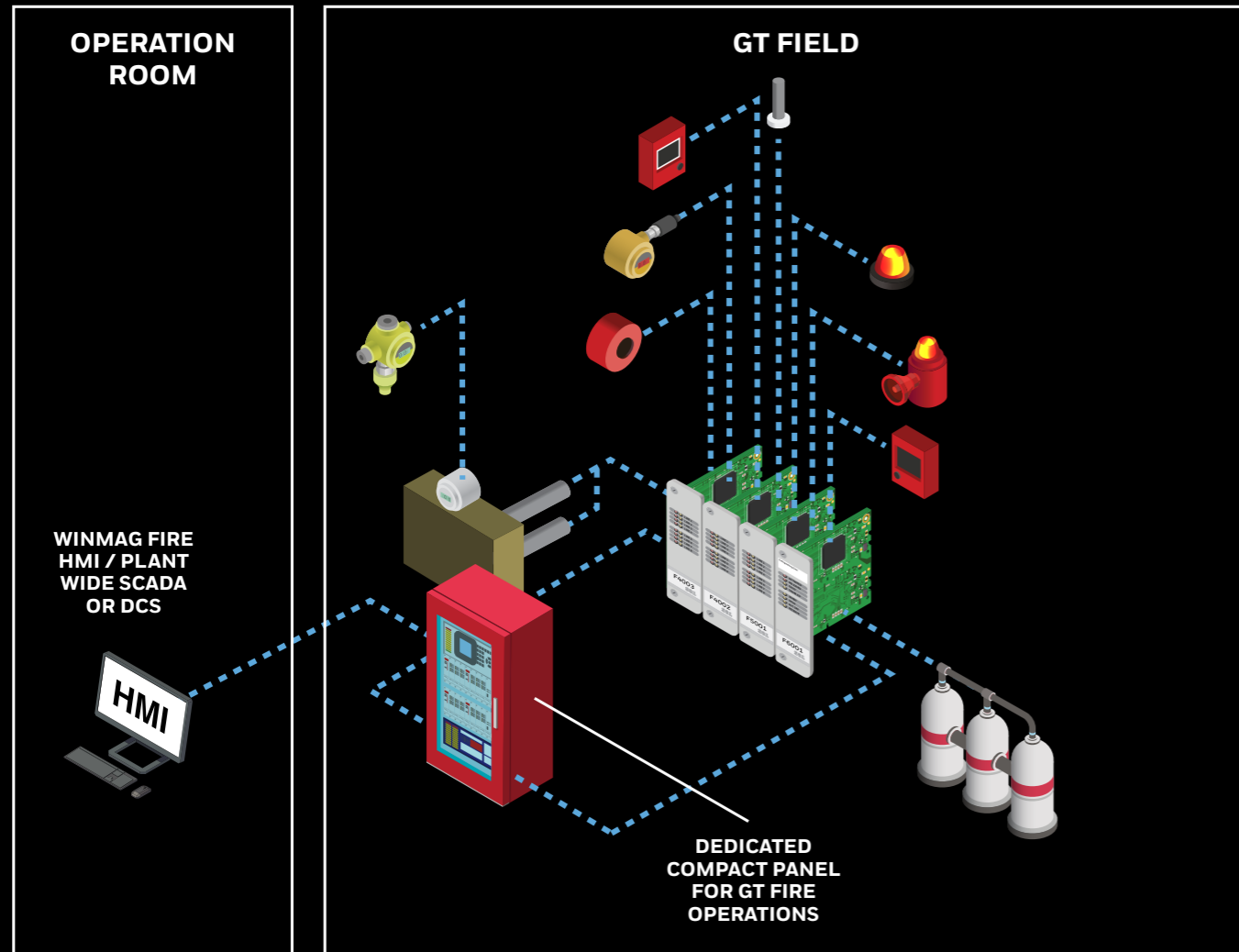

## GAS TURBINE NETWORK ARCHITECTURE

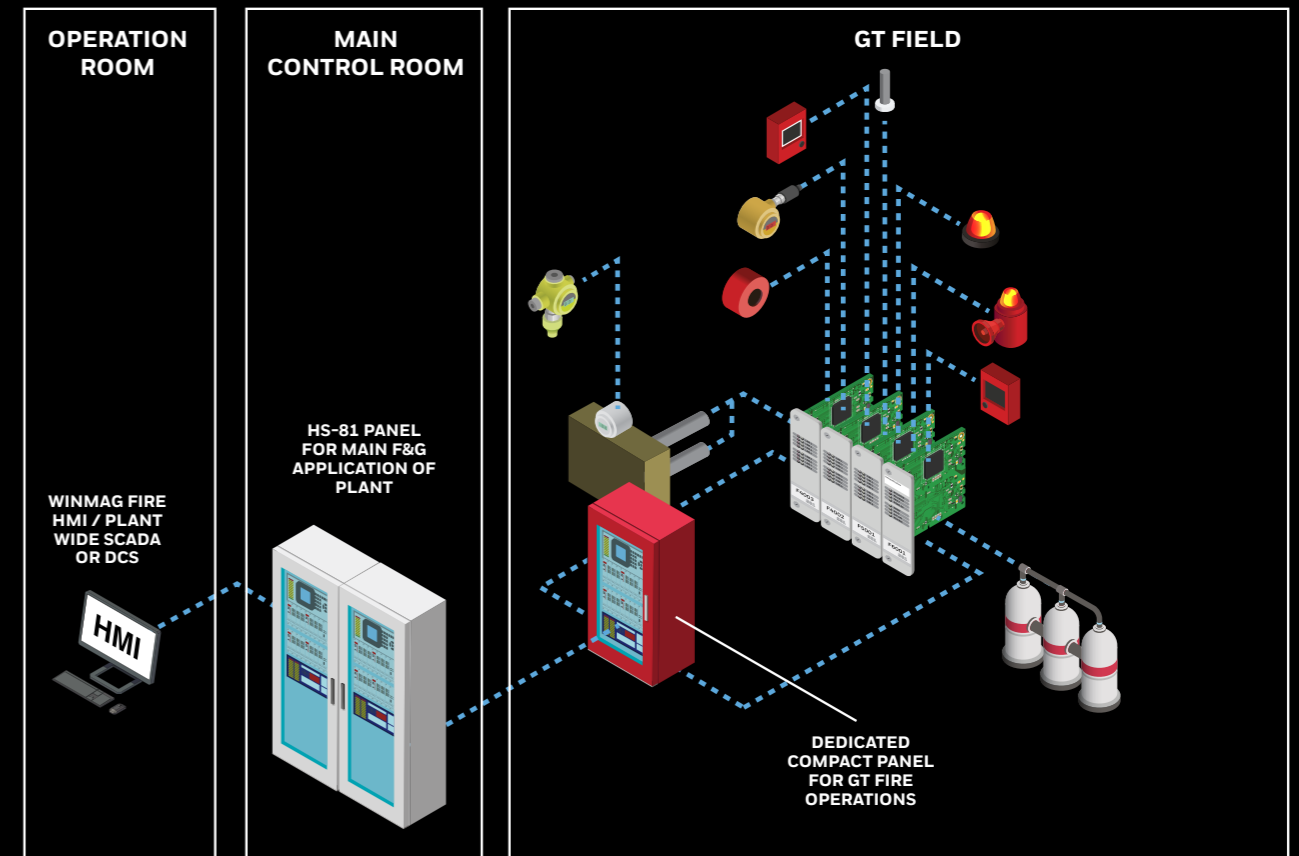

## GAS TURBINE NETWORK ARCHITECTURE VIA REMOTE I/O

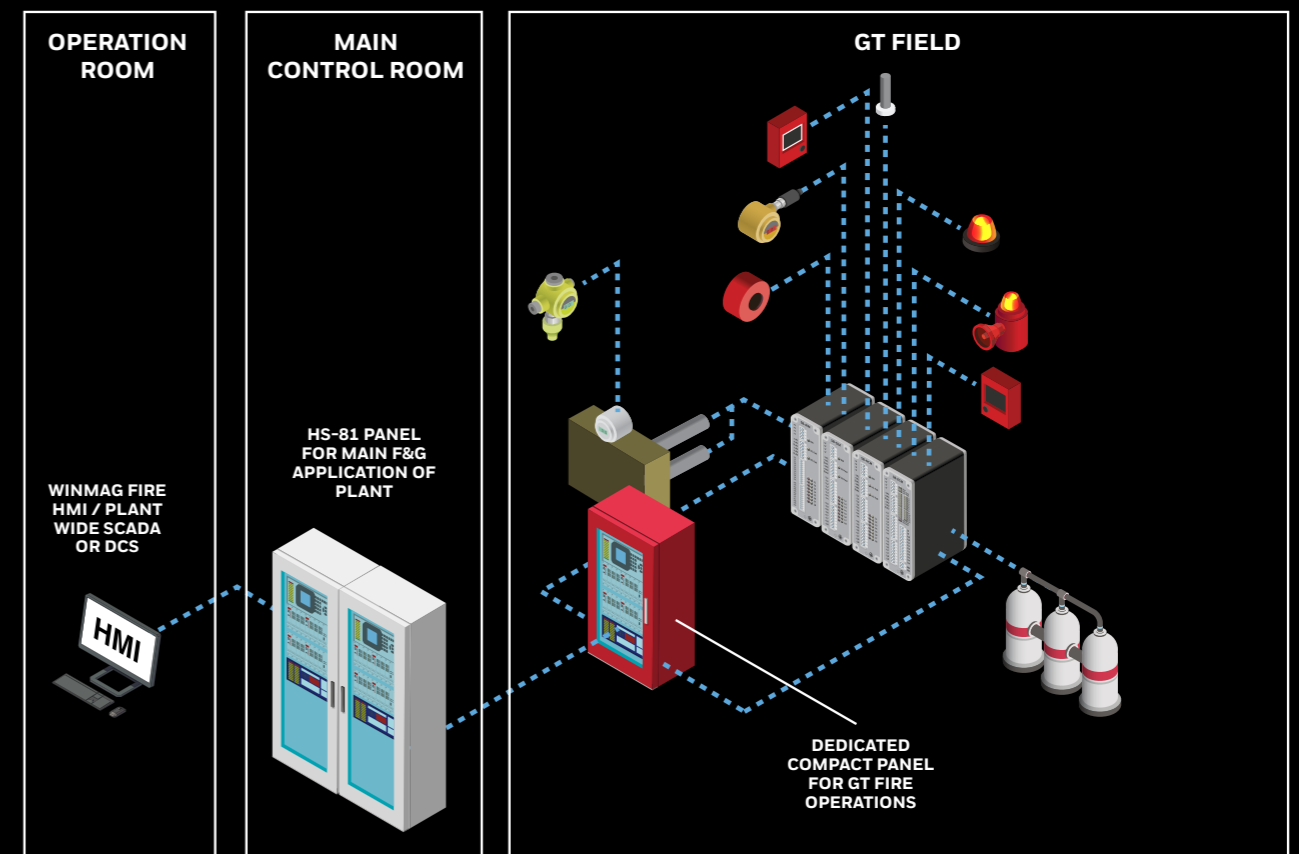



# HAVE CONFIDENCE THAT YOU MADE THE RIGHT CHOICE

Today there are a number of different flame and gas detection techniques in a variety of configurations that can be paired with sophisticated control equipment.

This armory of detection lets you select a device that will provide the right type of solution for your application.

**Call your Industrial Fire representative today and find out what your facility can achieve when you have Honeywell flame and gas detection solutions working for you.**

## Honeywell Industrial Fire

Via Lombardia 5

20004 Arluno (Milan) Italy

Tel: +39 02 36017829

E-mail: [industrialfire@honeywell.com](mailto:industrialfire@honeywell.com)

[industrialfire.honeywell.com](http://industrialfire.honeywell.com)



HIF-BR-GasTurbine | Rev 04 | 05/21  
© 2021 Honeywell International Inc.

**Honeywell**

INDUSTRIAL FIRE SOLUTIONS